

LMT121

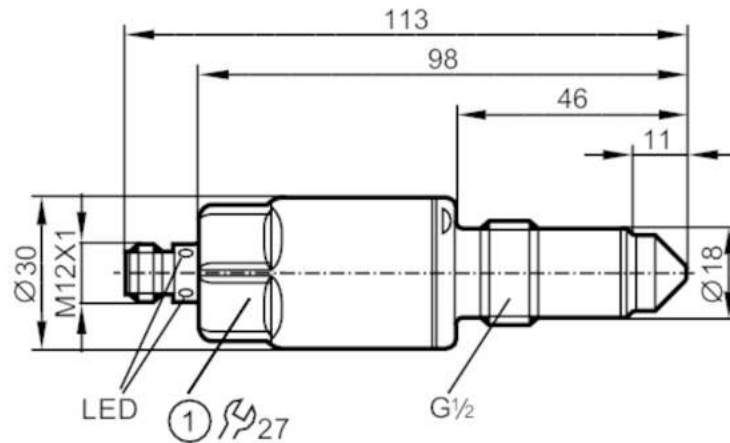

Sensor for point level detection

LMACE-A12E-QSKG-2/US



1 Tightening torque 20...25 Nm



ACS



EC 1935/2004

EHDG Certified

FCM



Reg31

Application	
Media	Liquids; viscous media; powder
Cannot be used for	See the operating instructions, chapter "Function and features".
Probe length [mm]	11
Tank pressure [bar]	-1...40; (MAWP (for applications according to CRN): 40 bar / 4 MPa)
MAWP (for applications according to CRN) [bar]	40
Oil	
Medium temperature [°C]	-40...100
Medium temperature short time [°C]	-40...150; (1 h)
Water	
Medium temperature [°C]	-40...100
Medium temperature short time [°C]	-40...150; (1 h)
Electrical data	
Operating voltage [V]	18...30 DC
Current consumption [mA]	< 50
Protection class	III
Reverse polarity protection	yes
Inputs / outputs	
Number of inputs and outputs	Number of digital outputs: 2

LMT121



Sensor for point level detection

LMACE-A12E-QSKG-2/US

Outputs	
Total number of outputs	2
Output signal	switching signal; IO-Link
Electrical design	PNP/NPN
Number of digital outputs	2
Output function	normally open / normally closed; (parameterisable)
Max. voltage drop switching output DC [V]	2.5
Permanent current rating of switching output DC [mA]	100
Short-circuit protection	yes
Type of short-circuit protection	pulsed
Overload protection	yes

Measuring/setting range	
Factory setting	media with low water content

Interfaces	
Communication interface	IO-Link
Transmission type	COM2 (38,4 kBaud)
IO-Link revision	1.1
SDCI standard	IEC 61131-9
IO-Link device ID	0x000132
Profiles	Smart Sensor: Process Data Variable; Device Identification
SIO mode	yes
Required master port type	A
Process data analogue	1
Process data binary	2
Min. process cycle time [ms]	2.3

Operating conditions	
Ambient temperature [°C]	-40...85
Note on ambient temperature	Medium temperature: < 100 °C
	-40...60 °C
Storage temperature [°C]	Medium temperature: < 150 °C
	-40...85
Protection	IP 68; IP 69K

Tests / approvals		
EMC	DIN EN 61000-6-2	
	DIN EN 61000-6-4	: open tanks
	DIN EN 61000-6-3	: closed tanks
Shock resistance	DIN EN 60068-2-27	50 g (11 ms)
Vibration resistance	DIN EN 60068-2-6	20 g (10...2000 Hz)
MTTF [years]	223	
UL approval	UL Approval no.	H001

LMT121



Sensor for point level detection

LMACE-A12E-QSKG-2/US

Mechanical data

Weight	[g]	211
Materials		stainless steel (1.4404 / 316L); PEEK; PEI; FKM
Materials (wetted parts)		PEEK
Process connection		G 1/2 external thread
Surface characteristics Ra/Rz of the wetted parts		< 0.8

Displays / operating elements

Display	switching status	LEDs, yellow
	operating status	LEDs, green

Remarks

Pack quantity	1 pcs.
---------------	--------

Electrical connection

Connector: 1 x M12; Contacts: gold-plated



Connection

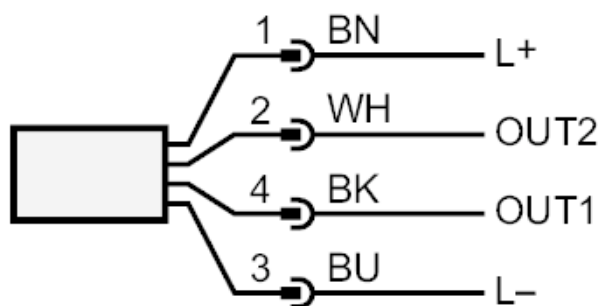

OUT1: switching output IO-Link Teach

OUT2: switching output

colours to DIN EN 60947-5-2

Core colours :

BK = black

BN = brown

BU = blue

WH = white