

| Technical parameter | | |
|-----------------------------|--------------|-------------|
| | Inner shell | Outer shell |
| Material | SUS304 | SUS304 |
| Thickness | 3mm | 2mm |
| Heating area m ² | 4.0 | |
| Insulation | Mineral wool | |
| Total volume | 3170 L | |
| Working volume | 2400 L | |

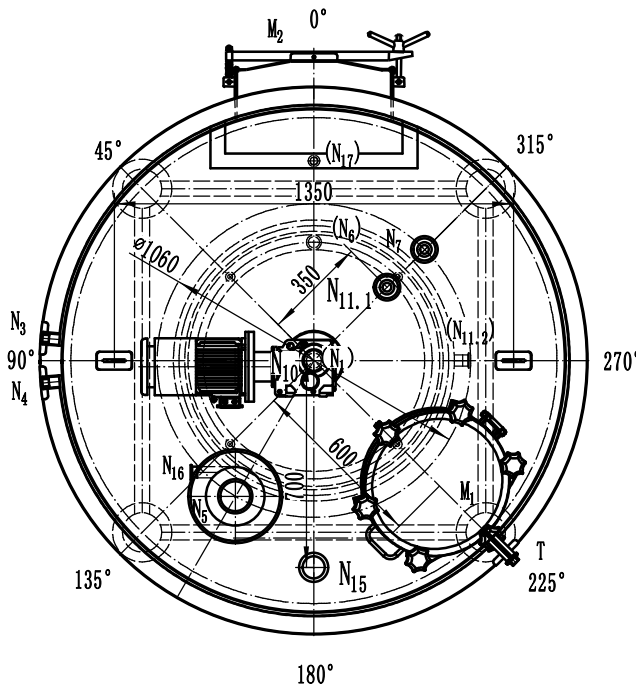

| Specification | | | |
|-------------------|-----------|------------------|---------------------|
| Symbol | Spec | Connecting Style | Usage |
| M ₁ | ø450 | Welding | Glass manway |
| M ₂ | 535x415 | Welding | Side Manway |
| N ₁ | 2" | Tri-clamp | Outlet |
| N ₃ | 1" | NPT | Condensation outlet |
| N ₄ | 1" | NPT | Steam inlet |
| N ₅ | 4" | Tri-clamp | Hydrator |
| N ₆ | 1.5" | Tri-clamp | Wort outlet |
| N ₇ | 3"-1.5" | Tri-clamp | Sparge |
| N ₁₀ | / | / | Reducer (1.5KW) |
| N _{11.1} | 3"-1.5" | Tri-clamp | Spray ball |
| N _{11.2} | 1.5" | Tri-clamp | Flush nozzles |
| N ₁₅ | 4" | Bevel seat | Tank light |
| N ₁₆ | 1.5" | Tri-clamp | Water inlet |
| T | 1.5"-0.5" | Tri-clamp/NPT | Thermowell |
| N ₁₇ | 1" | NPT | Outlet |

THE INFORMATION CONTAINED IN THIS DRAWING IS THE SOLE PROPERTY OF YOLONG INDUSTRIAL CO., LTD. > ANY REPRODUCTION IN PART OR AS A WHOLE WITHOUT THE WRITTEN PERMISSION OF <INSERT COMPANY NAME HERE> IS PROHIBITED.

| | |
|-----------------------|-------------|
| Project No. | |
| Drawing No. | |
| Version No. | V1.6 |
| Customer Confirmation | |
| Designer | Eason Chang |
| Draft man | |
| Proofreading | |
| Reviewer | |
| Date | 2018.08.20 |
| Date | |
| Date | |
| Date | |

2400L Mash&Lauter

SUS304

| | | | |
|------------------------------------|----------|--------|-------|
| Drawing Mark | Quantity | Weight | Scale |
| | 1 | | 1:10 |
| Total | Page | page | |
| YOLong YOLONG INDUSTRIAL CO., LTD. | | | |