

THE INFORMATION CONTAINED IN THIS DRAWING IS THE SOLE PROPERTY OF
 YOLONG INDUSTRIAL CO., LTD. > ANY REPRODUCTION IN PART OR AS A WHOLE
 WITHOUT THE WRITTEN PERMISSION OF <INSERT COMPANY NAME HERE> IS PROHIBITED.

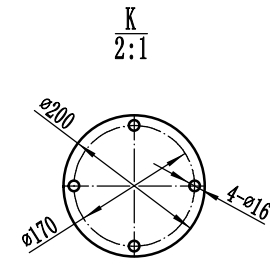

Technical parameter		
	Inner shell	Outer shell
Material	SUS304	SUS304
Thickness	3mm	2mm
Cooling area m ²	3.2	
Insulation	PU-Foam	
Total volume	17.5 bbL	
Working volume	15 bbL	
Net weight	340 Kg	

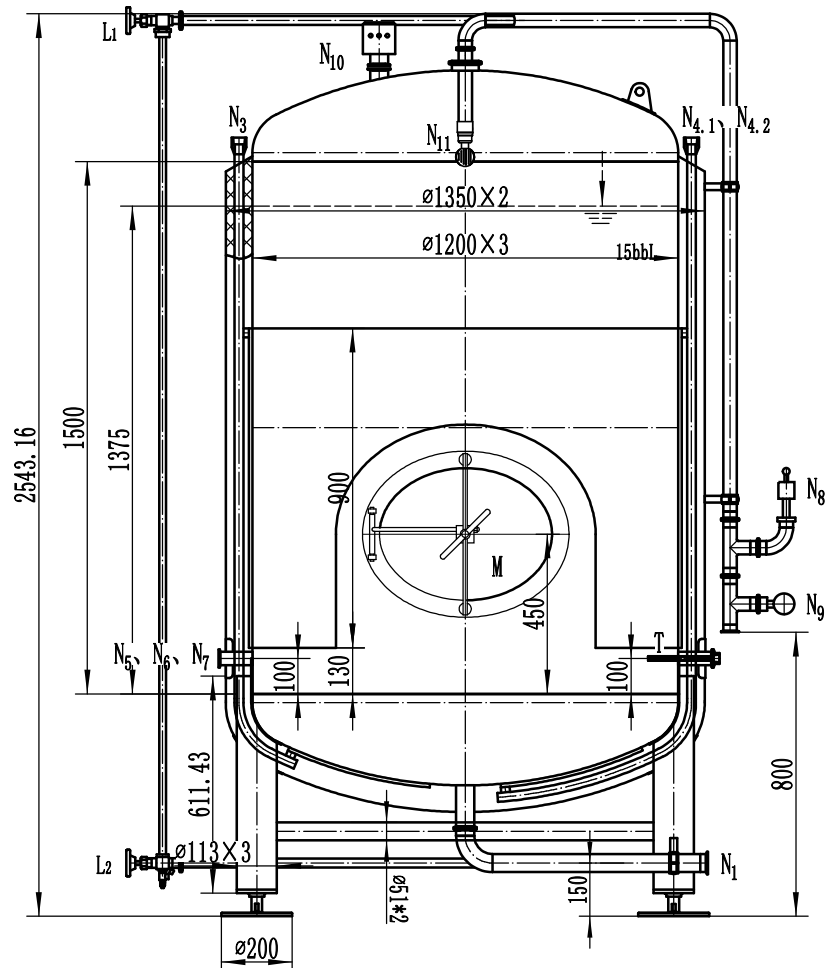
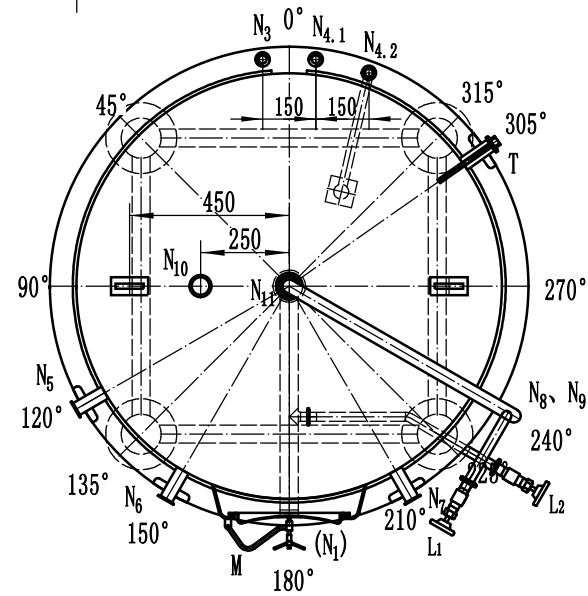

Specification

Symbol	Spec	Connecting Style	Usage
N ₁	2"	Tri-clamp	Outlet
N ₃	1"	NPT	Glycol outlet
N _{4.1-4.2}	0.75"	NPT	Glycol inlet
N ₅	1.5"	Tri-clamp	Carbon stone
N ₆	1.5"	Tri-clamp	Spare hole
N ₇	1.5"	Tri-clamp	Sample hole
N ₈	1.5"	Tri-clamp	Bung valve
N ₉	1.5"	Tri-clamp	pressure gauge
N ₁₀	2"	Tri-clamp	PVRV
N ₁₁	3"-1.5"	Tri-clamp	Cleaning hole
T	1.5"-0.5"	Tri-clamp/NPT	Thermowell
M	580*480	Welding	Manhole
L ₁ , L ₂	1"	Tri-clamp	level

Project No.			
Drawing No.			
Version No.	V1.3		
Customer Confirmation			
Designer	jason wang	Date	2018.11.22
Draft man		Date	
Proofreading		Date	
Reviewer		Date	

15bbL Serving tank-D1200

SUS304

YI-04-1106A17			
Drawing Mark	Quantity	Weight	Scale
			1:15
Total	Page	page	
YOLong YOLONG INDUSTRIAL CO., LTD.			