

Technical parameter		
	Inner shell	Outer shell
Material	SUS304	SUS304
Thickness	3mm	2mm
Insulation	Mineral wool	
MMLT Total volume	13.6 bbl	
Working volume	10 bbl	
Heating area m ²	2.4	
HLT Total volume	16.6 bbl	
Working volume	15 bbl	
Heating area m ²	3	

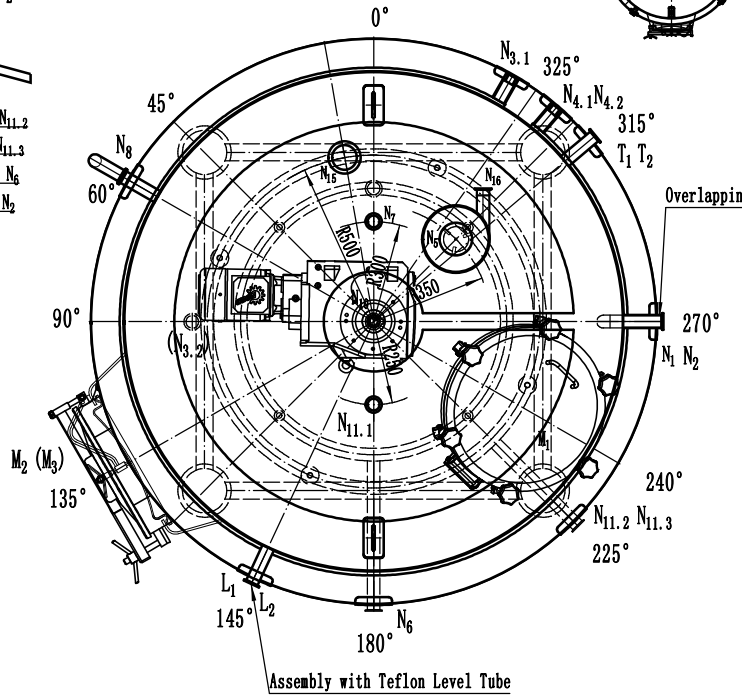
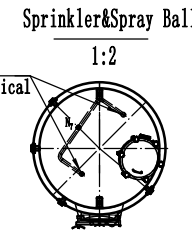
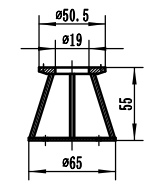
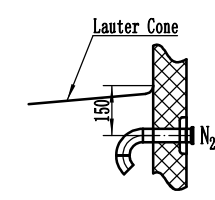
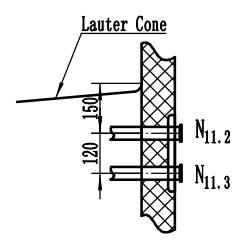
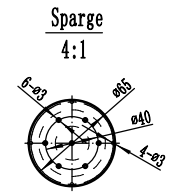
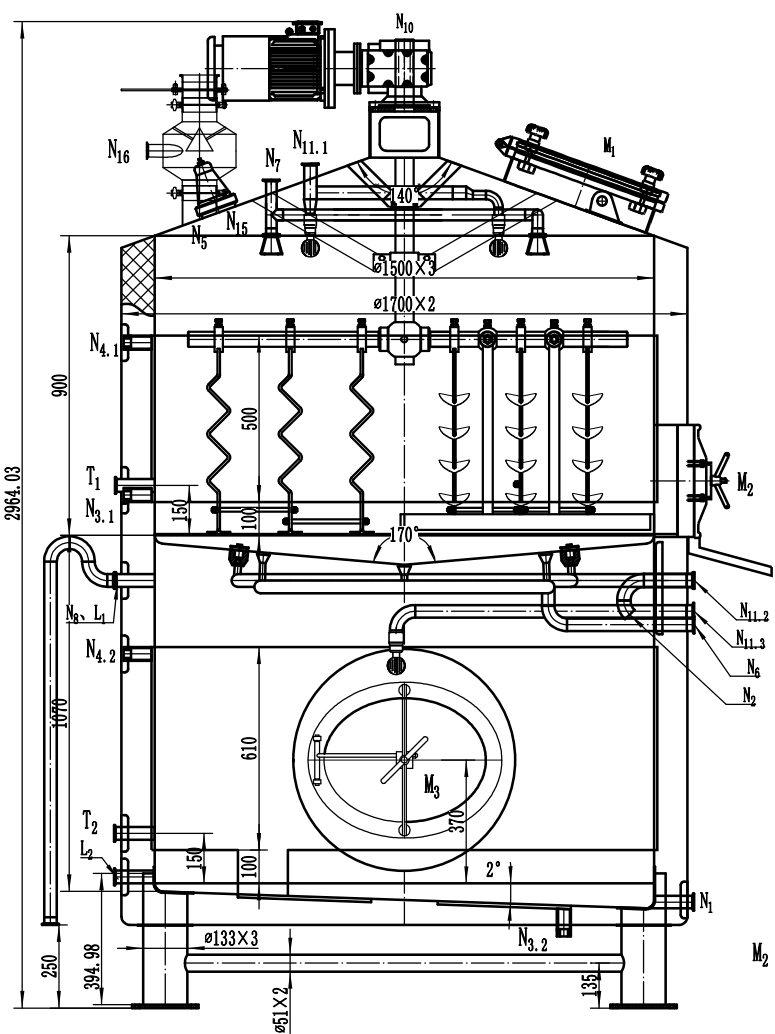

Specification

Symbol	Spec	Connecting Style	Usage
M ₁	ø450	Welding	Glass manway
M ₂	535x415	Welding	Side Manway
M ₃	580x480	Welding	Side Manway
N ₁	1.5"	Tri-clamp	Outlet
N ₂	1.5"	Tri-clamp	Water inlet
N _{3.1} -N _{3.2}	0.75"	NPT	Condensation outlet
N _{4.1} -N _{4.2}	0.75"	NPT	Steam inlet
N ₅	4"	Tri-clamp	Hydrator
N ₆	1.5"	Tri-clamp	Wort outlet
N ₇	1.5"	Tri-clamp	Sparge
N ₈	1.5"	Tri-clamp	Overflow
N ₁₀	/	/	Reducer (1.1KW)
N _{11.1}	1.5"	Tri-clamp	Spray ball
N _{11.2}	1.5"	Tri-clamp	Flush nozzles
N _{11.3}	1.5"	Tri-clamp	Spray ball
T ₁ -T ₂	1.5"	Tri-clamp	Thermowell
N ₅	4"	Bevel seat	Tank light
N ₁₆	1.5"	Tri-clamp	Water inlet
L ₁ -L ₂	1.5"	Tri-clamp	Level

Mark	Revision Text	Places	Partitioning	Rev. No.	Signature	Date	Mark	Revision Text	Places	Partitioning	Rev. No.	Signature	Date
1							1	all			V1.0	Vinson chang	2019.03.28

THE INFORMATION CONTAINED IN THIS DRAWING IS THE SOLE PROPERTY OF <YOLONG INDUSTRIAL CO., LTD.>. ANY REPRODUCTION IN PART OR AS A WHOLE WITHOUT THE WRITTEN PERMISSION OF <YOLONG INDUSTRIAL CO., LTD.> IS PROHIBITED.



客户图标	YI-04-0327A19
10hL MMLT&15hL HLT	1:16
图纸编号	10hL MMLT&15hL HLT-D1450
第 页 / 共 页	